



## **100G QSFP28 Single Lambda LR1-20-BiDi Transceiver** **Hot Pluggable, Bidi LC, Tx1291nm EML / Rx1311nm, SMF 20KM, DDM**

**Part Number: FQ2S-K8-C29-20D**



### **Overview**

FQ2S-K8-C29-20D is a QSFP28 Single Lambda BiDi transceiver for 100GbE applications especially in Datacom, Data Center & Storage networks applications. It works based on the 100G Lambda MSA 100G-LR1-20 Standard with the typical center wavelength 1291nm. The transceiver incorporates one channel optical signal of 100Gbps(PAM4) from four channels electrical signal of 25Gbps(NRZ) and vice versa up to SMF 20km optical links.

### **Applications**

- 100GBASE Ethernet
- Data Centers Switch Interconnect
- Server and Storage Area Network Interconnect

### **Features**

- Compliant with SFF-8665 QSFP28 MSA
- Compliant with IEEE 802.3bm CAUI-4 Interface
- Compatible with 100GBASE-LR1-20
- Signal Conversion between 53.125GBd PAM4 optical signal and 25.78125Gbps NRZ electrical signal with DSP Gear Box.
- Built in Tx CDR and Rx CDR
- Inbuild KP4 FEC
- Hot Pluggable QSFP28 footprint
- CWDM 1291nm EML transmitter
- Simplex LC connector
- 2-wire interface for management and diagnostic monitor compliant with SFF-8636
- Single 3.3V power supply
- Link distance 20km over SM fiber with FEC
- Maximum Power consumption 4.5W
- RoHS compliant



## Laser Safety

- This is a Class 1 Laser Product complies with 21 CFR 1040.10 and 1040.11 except for conformance with IEC 60825-1 Ed. 3., as described in Laser Notice No. 56, dated May 8, 2019.
- Caution: Use of control or adjustments or performance of procedure other than those specified herein may result in hazardous radiation exposure.

## Absolute Maximum Ratings

Parameters	Symbol	Min.	Max.	Unit
Storage Temperature	T <sub>ST</sub>	-40	+85	°C
Storage Relative Humidity	RH	5	95	%
Supply Voltage	V <sub>CC3</sub>	-0.5	+3.6	V

## Recommended Operating Conditions

Parameters	Symbol	Min.	Typ.	Max.	Unit
Case Operating Temp. (FQ2S-K8-C29-20D)	T <sub>OP</sub>	0	-	+70	°C
Case Operating Temp. (FQ2S-K8-C29-20Di)	T <sub>OP</sub>	-40	-	+85	°C
Supply Voltage	V <sub>CC</sub>	+3.13	+3.3	+3.47	V
Supply Current	I <sub>CC</sub>			1360	mA
Electrical Data Rate, per Lane (NRZ)	DR <sub>ELE</sub>		25.78125		Gb/s
Optical Data Rate (PAM4)	DR <sub>OPT</sub>		53.125		GBd
Data Rate Accuracy	ΔDR	-100		+100	ppm
Pre-FEC Bit Error Rate	BER <sub>PRE</sub>			2.4x10 <sup>-4</sup>	
Post-FEC Bit Error Rate	BER <sub>POST</sub>			1x10 <sup>-12</sup>	
Power Consumption	P			4.5	W
Transceiver Power-on Initialization Time				2000	ms
Control Input Voltage High	V <sub>IH</sub>	2.0		V <sub>CC</sub>	V
Control Input Voltage Low	V <sub>IL</sub>	0		0.8	V
Fiber Link Distance (G.652 SMF)	D			20	km



## Transmitter Electro-optical Characteristics

$V_{CC} = 3.13V$  to  $3.47V$ ,  $T_{OP} = 0\text{ }^{\circ}C$  to  $70\text{ }^{\circ}C$ (FQ2S-K8-C29-20D);  $T_{OP} = -40\text{ }^{\circ}C$  to  $85\text{ }^{\circ}C$ (FQ2S-K8-C29-20Di)

Parameters	Symbol	Min.	Typ.	Max.	Unit	Note
Optical Center Wavelength	$\lambda_c$	1284.5	1291	1297.5	nm	
Average Launch Power	$P_{AVG}$	-0.2		+6.6	dBm	
Optical Modulation Amplitude (OMA)	TDECQ < 1.4dB	$P_{OMA}$	+2.8		+6.8	dBm
	TDECQ > 1.4dB.		1.4+ TDECQ		+6.8	dBm
Transmitter and Dispersion Eye Closure	TDECQ			3.6	dB	
Spectral Width (-20dB)	$\Delta\lambda$			1	nm	
Side Mode Suppression Ratio	SMSR	30			dB	
Optical Extinction Ratio	ER	3.5			dB	
Relative Intensity Noise	RIN			-136	dB/Hz	
Average Launch Power OFF	$P_{OFF}$			-30	dBm	
Optical Return Loss Tolerance	ORLT			15.6	dB	
Transmitter Reflectance	$R_{TX}$			-26	dB	
Input Differential Impedance	$Z_{IN}$	90	100	110	$\Omega$	
Differential Data Input Voltage	$V_{IN-PP}$	900			mVpp	
Common Mode Voltage (Vcm)	TP1	-350		2850	mV	
Transition Time (20~80%)	TP1a	10			ps	
Eye Width at 1E-15	TP1a	0.46			UI	
Eye Height at 1E-15, Differential	TP1a	95			mV	



## Receiver Electro-optical Characteristics

$V_{CC} = 3.13V$  to  $3.47V$ ,  $T_{OP} = 0\text{ }^{\circ}C$  to  $70\text{ }^{\circ}C$ (FQ2S-K8-C29-20D);  $T_{OP} = -40\text{ }^{\circ}C$  to  $85\text{ }^{\circ}C$ (FQ2S-K8-C29-20Di)

Parameters	Symbol	Min.	Typ.	Max.	Unit	Note
Optical Center Wavelength	$\lambda_c$	1304.5	1311	1317.5	nm	
Damage Threshold	D <sub>TH</sub>	+7.6			dBm	1
Average Receive Power	P <sub>RX-AVG</sub>	-10		+6.6	dBm	
Receiver Power (OMA <sub>outer</sub> )	P <sub>RX-OMA</sub>			+6.8	dBm	
Receiver Sensitivity (OMA <sub>outer</sub> )	SEN <sub>OMA</sub>			Max(-7.6, SECQ-9)	dBm	2
Stressed Receiver Sensitivity	SRS			-5.4	dBm	
Receiver Reflectance	R <sub>RX</sub>			-26	dB	
LOS De-Assert	LOS <sub>D</sub>			-12	dBm	
LOS Assert	LOS <sub>A</sub>	-15			dBm	
LOS Hysteresis	LOS <sub>HY</sub>	0.5			dB	
Output Differential Impedance	Z <sub>OUT</sub>	90	100	110	$\Omega$	
Differential Data Output Voltage	V <sub>OUT-PP</sub>			900	mVpp	
Common Mode Voltage (V <sub>cm</sub> )	TP4	-350		2850	mV	
Transition Time (20~80%)	TP4	10			ps	
Eye Width at 1E-15	TP4	0.57			UI	
Eye Height at 1E-15, Differential	TP4	228			mV	

**Note1:** The receiver shall be able to tolerate, without damage, continuous exposure to a modulated optical input signal having this power level on one lane. The receiver does not have to operate correctly at this input power.

**Note2:** Sensitivity is specified at  $2.4 \times 10^{-4}$  BER with PRBS31Q.



## Transceiver Block Diagram

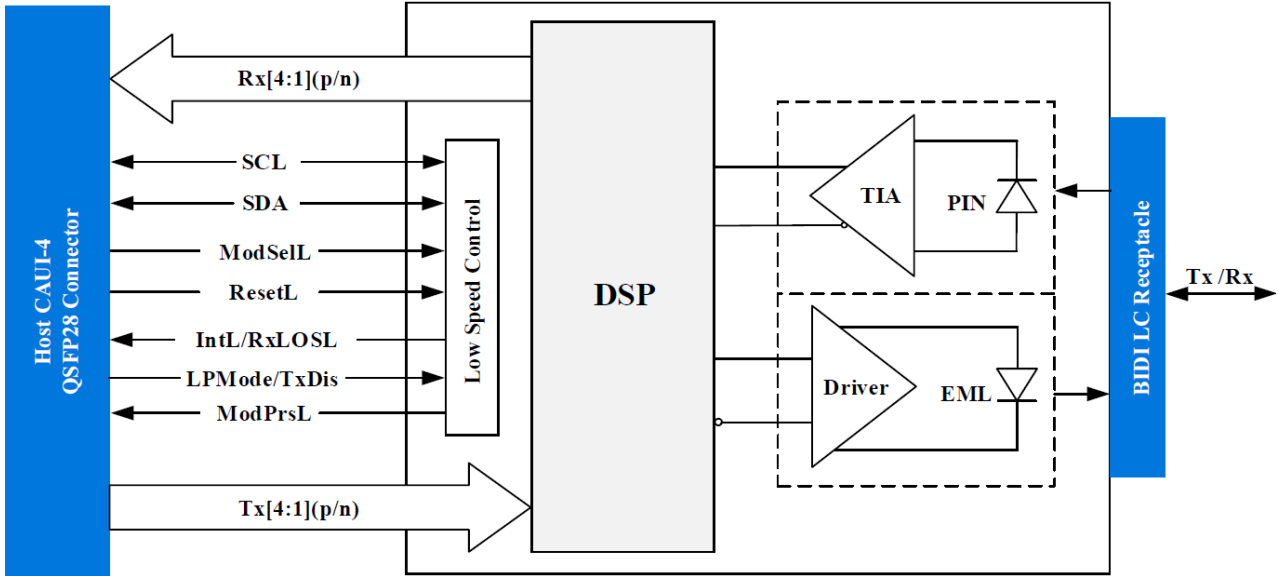

## Pin Assignment

38	GND	
37	Tx1n	
36	Tx1p	
35	GND	
34	Tx3n	
33	Tx3p	
32	GND	
31	LP Mode	
30	Vcc1	
29	VccTx	
28	IntL	
27	ModPrsL	
26	GND	
25	Rx4p	
24	Rx4n	
23	GND	
22	Rx2p	
21	Rx2n	
20	GND	

Top Side  
Viewed From Top

Module Card Edge

	GND	1
	Tx2n	2
	Tx2p	3
	GND	4
	Tx4n	5
	Tx4p	6
	GND	7
	ModselL	8
	ResetL	9
	VccRx	10
	SCL	11
	SDA	12
	GND	13
	Rx3p	14
	Rx3n	15
	GND	16
	Rx1p	17
	Rx1n	18
	GND	19

Bottom Side  
Viewed From Bottom



## Pin Description

Pin	Logic	Name	Function / Description
1		GND	Module Ground
2	CML-I	Tx2n	Transmitter Inverted Data Input
3	CML-I	Tx2p	Transmitter Non-Inverted Data Input
4		GND	Module Ground
5	CML-I	Tx4n	Transmitter Inverted Data Input
6	CML-I	Tx4p	Transmitter Non-Inverted Data Input
7		GND	Module Ground
8	LVTLL-I	ModSelL	Module Select
9	LVTLL-I	ResetL	Module Reset
10		VccRx	+3.3V Power Supply Receiver
11	LVC MOS-I/O	SCL	2-Wire Serial Interface Clock
12	LVC MOS-I/O	SDA	2-Wire Serial Interface Data
13		GND	Module Ground
14	CML-O	Rx3p	Receiver Non-Inverted Data Output
15	CML-O	Rx3n	Receiver Inverted Data Output
16		GND	Module Ground
17	CML-O	Rx1p	Receiver Non-Inverted Data Output
18	CML-O	Rx1n	Receiver Inverted Data Output
19		GND	Module Ground
20		GND	Module Ground
21	CML-O	Rx2n	Receiver Inverted Data Output
22	CML-O	Rx2p	Receiver Non-Inverted Data Output
23		GND	Module Ground
24	CML-O	Rx4n	Receiver Inverted Data Output
25	CML-O	Rx4p	Receiver Non-Inverted Data Output
26		GND	Module Ground
27	LVTLL-O	ModPrsL	Module Present
28	LVTLL-O	IntL	Interrupt
29		VccTx	+3.3V Power Supply Transmitter
30		Vcc1	+3.3V Power Supply
31	LVTLL-I	LPMODE	Low Power Mode
32		GND	Module Ground



33	CML-I	Tx3p	Transmitter Non-Inverted Data Input
34	CML-I	Tx3n	Transmitter Inverted Data Input
35		GND	Module Ground
36	CML-I	Tx1p	Transmitter Non-Inverted Data Input
37	CML-I	Tx1n	Transmitter Inverted Data Input
38		GND	Module Ground

**Note1:** GND is the symbol for signal and supply (power) common for QSFP28 modules. All are common within the QSFP28 module and all module voltages are referenced to this potential unless otherwise noted. Connect these directly to the host board signal common ground lane.

**Note2:** VccRx, Vcc1 and VccTx are the receiver and transmitter power suppliers and shall be applied concurrently. Recommended host board power supply filtering is shown below. Vcc Rx, Vcc1 and Vcc Tx may be internally connected within the QSFP28 transceiver module in any combination. The connector pins are each rated for a maximum current of 1000mA..

## Recommended Power Supply Filter

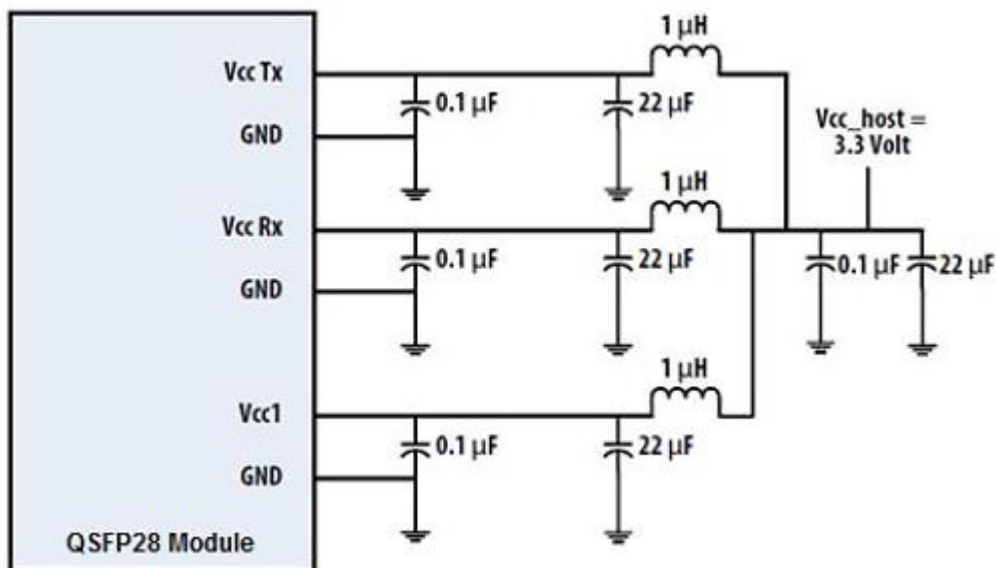



## Digital Diagnostic Functions

As defined by the QSFP28 MSA, Ficer's QSFP28 transceivers provide digital diagnostic functions via a 2-wire serial interface, which allows real-time access to the following operating parameters:

- Transceiver temperature
- Laser bias current (4-Channel)
- Transmitted optical power (4-Channel)
- Received optical power (4-Channel)
- Transceiver supply voltage

It also provides a sophisticated system of alarm and warning flags, which may be used to alert end-users when particular operating parameters are outside of a factory-set normal range.

The operating and diagnostics information is monitored and reported by a Digital Diagnostics Controller (DDC) inside the transceiver, which is accessed through the 2-wire serial interface. When the serial protocol is activated, the serial clock signal (SCL pin) is generated by the host. The positive edge clocks data into the QSFP28 transceiver into those segments of its memory map that are not write-protected. The negative edge clocks data from the QSFP28 transceiver. The serial data signal (SDA pin) is bi-directional for serial data transfer. The host uses SDA in conjunction with SCL to mark the start and end of serial protocol activation. The memories are organized as a series of 8-bit data words that can be addressed individually or sequentially. The 2-wire serial interface provides sequential or random access to the 8 bit parameters, addressed from 000h to the maximum address of the memory.

For more detailed information including memory map definitions, please see the QSFP28 MSA Specification.

## Digital Diagnostic Memory Map



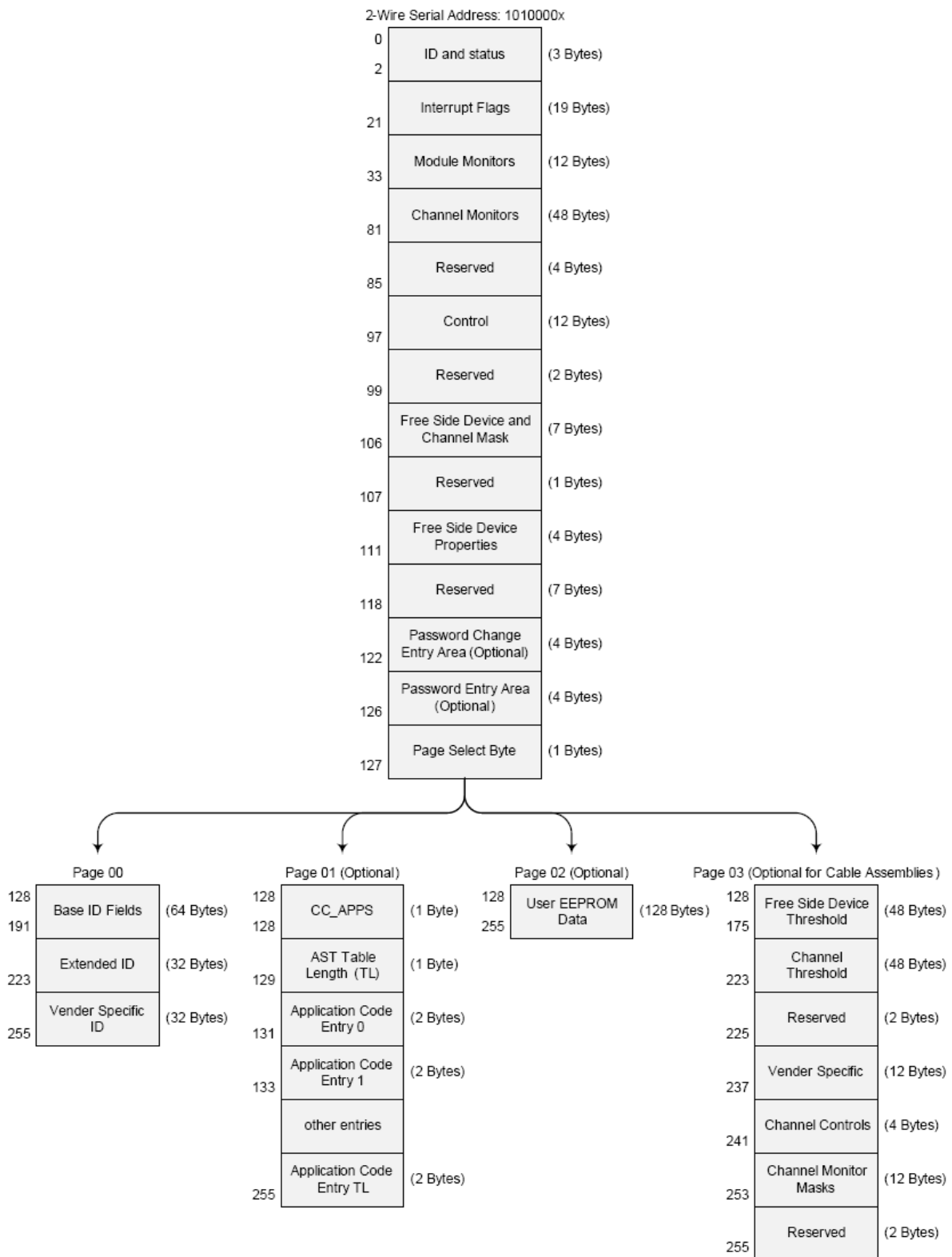



## Mechanical Dimensions

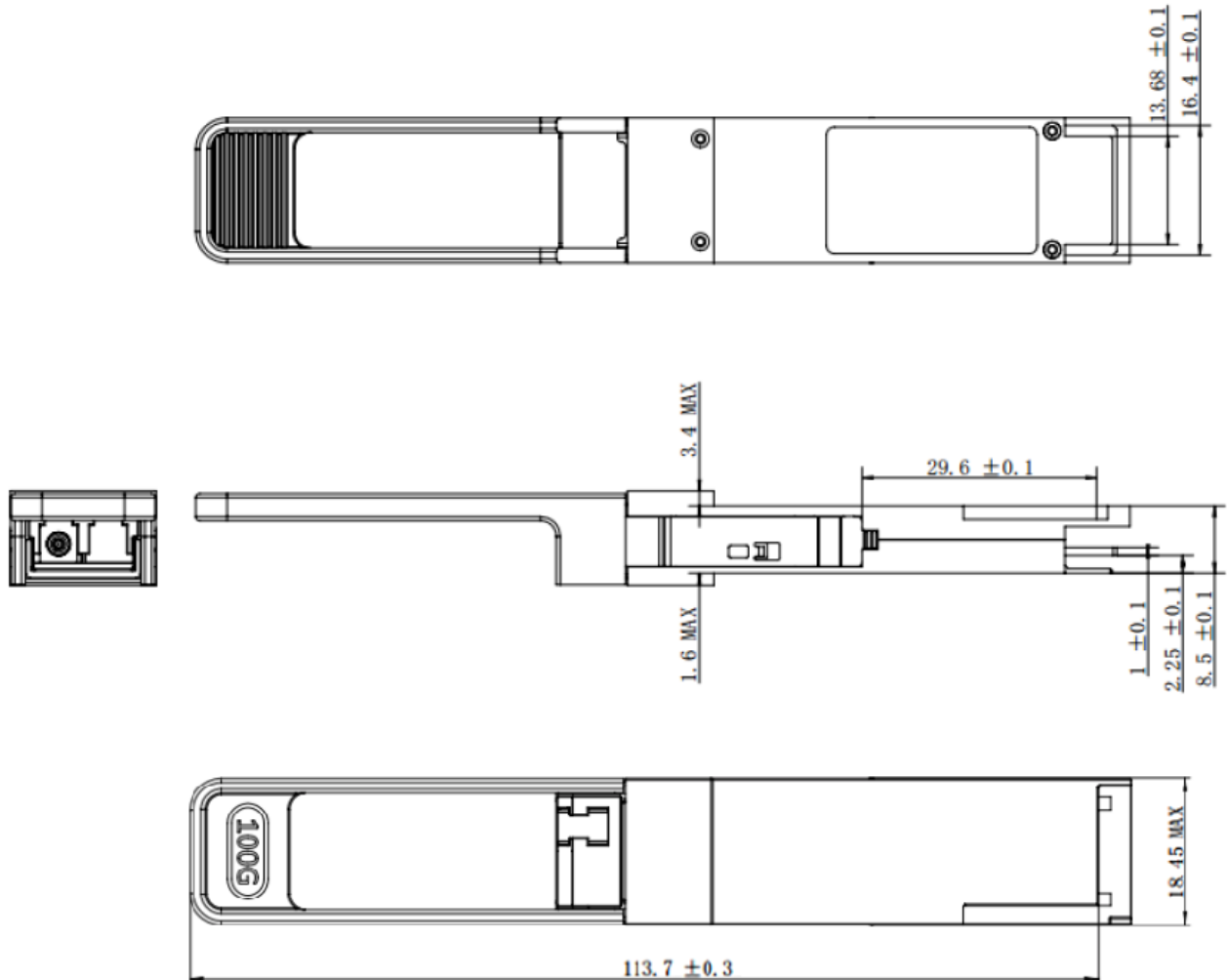

(All Dimensions are ±0.20mm Unless Otherwise Specified, Unit: mm)

## Ordering Information

Part No.	Tx	Rx	Link	DDM	Temp.
FQ2S-K8-C29-20D	1291 nm	1311 nm	20km (with FEC)	Yes	0~70°C
FQ2S-K8-C29-20Di					-40~85°C

**Note1:** Distances are indicative only. To calculate a more precise link budget based on specific conditions in your application, please refer to the optical characteristics.